



SUBARU

*INSTALLATION
INSTRUCTIONS*

SUBARU

PART NUMBER: E551SSG200

DESCRIPTION: FORESTER FRONT BUMPER UNDER GUARD

KIT CONTENTS:

A.

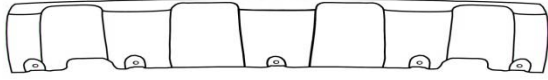

Front Bumper Under
Guard x 1

B.



Push Retainer
x 5

C.



Alcohol Wipe
x 1

TOOLS REQUIRED:

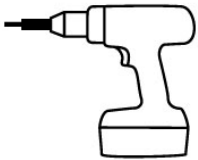

Drill with 5/16" Drill Bit
and 1/2" Drill Stop

PART NUMBER:
E551SSG200

ISSUE:
00

DATE:
11-2-12

SUBARU OF AMERICA

PAGE
1/3

MEANING OF CHARACTERS:

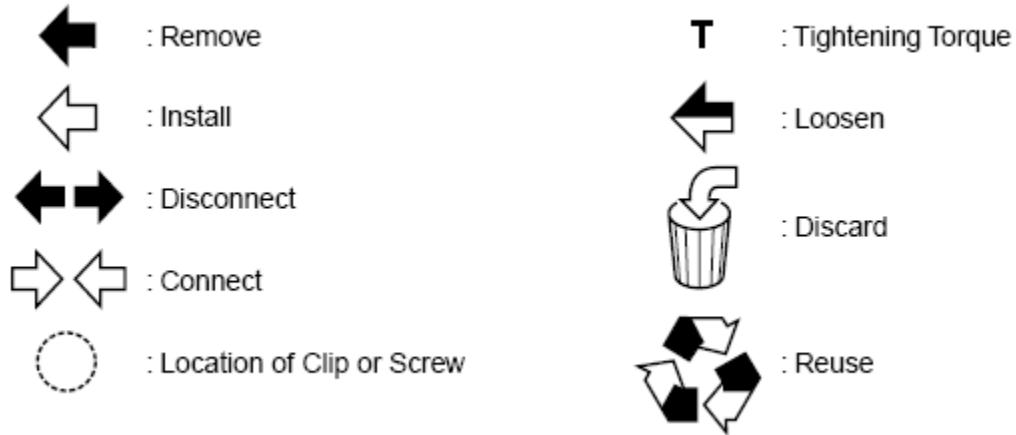

Surface Preparation

1

Make sure that all installation surfaces (shown below) are clean, free of dirt, grease, and debris. Use a supplied isopropyl alcohol based wipe (C). Inspect vehicle for damage before installation of front bumper under guard. Before beginning, vehicle and under guard must be at room temperature. If the temperature is below 60 F (16 C) or above 110 F (43 C), let vehicle sit indoors until the bumper and under guard are room temperature.

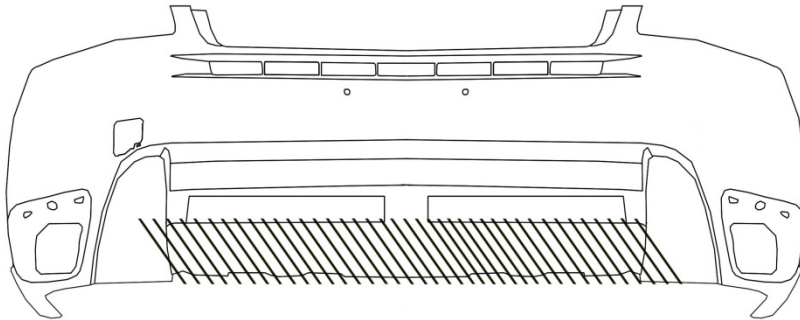

Front Molding Installation

2

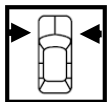

Position Front Bumper Under Guard (A) on bumper with the tape tabs accessible.

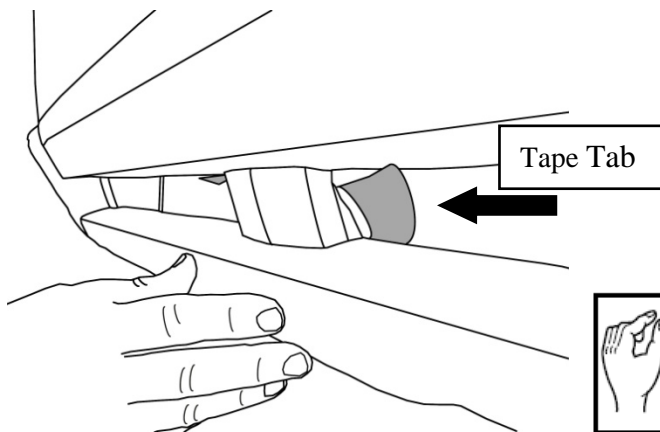

3

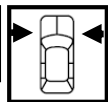

Pull tape liner from center position to end of part. Verify position of part and press into place, applying 30 psi of pressure for a minimum of 10 seconds. Allow 24 hours for maximum bond.

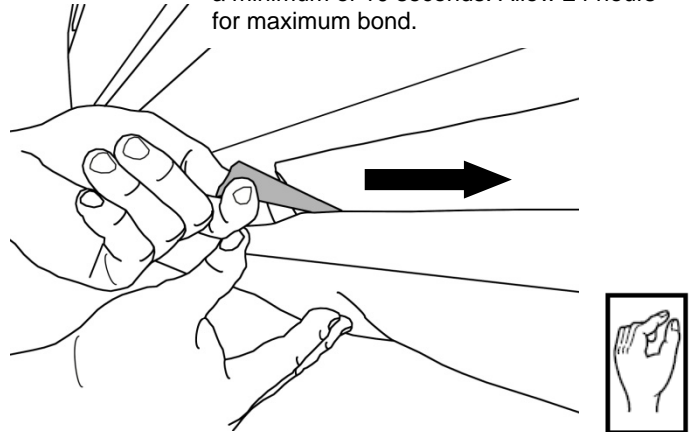

4

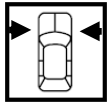

While holding part firmly in place with no gap on ends, using a 5/16" drill bit with 1/2" drill stop, drill (5) 5/16" mounting holes through the existing holes in the underside of the part and into the bumper at the indicated locations.

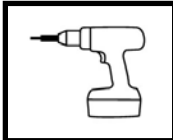
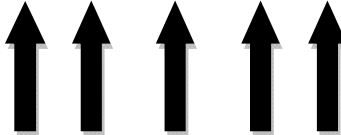
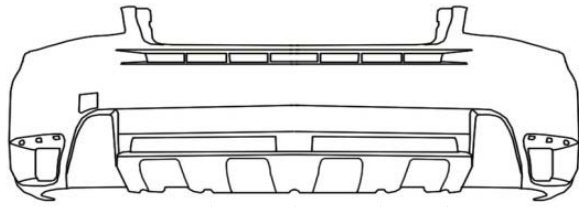

5

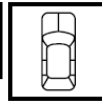

Install push retainer clips (B) through holes in underside of part and into vehicle.

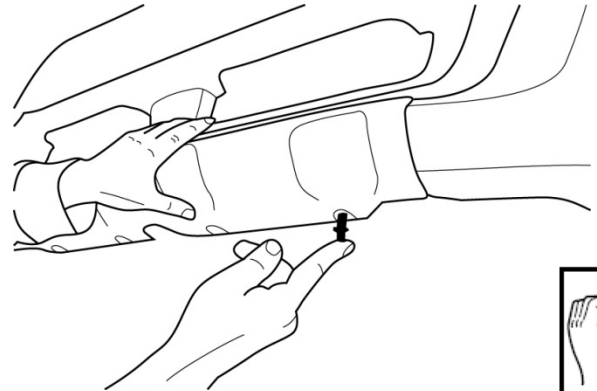

6

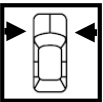

Installation Complete

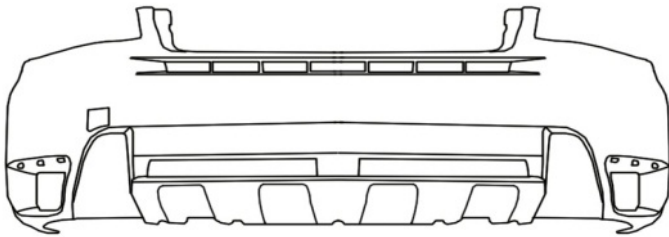



SUBARU

*INSTRUCTIONS
D'INSTALLATION*

SUBARU

NUMÉRO DE PIÈCE : E551SSG200

DESCRIPTION : ÉCRAN INFÉRIEUR DE PARE-CHOCS AVANT – FORESTER

CONTENU DE LA

A.

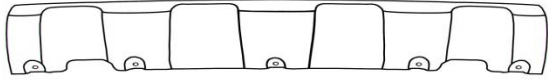

Écran inférieur de pare-
chocs avant x 1

B.



Cheville
x 5

C.



Lingette imbibée
d'alcool
x 1

OUTILS REQUIS :

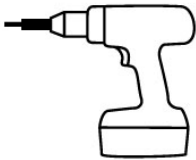

Perceuse avec mèche
de 5/16 po et butée de
perçage de 1/2 po

NUMÉRO DE PIÈCE :
E551SSG200

VERSION :
00

DATE :
2012-11-2

SUBARU OF AMERICA

PAGE
1/3

SIGNIFICATION DES SYMBOLES :

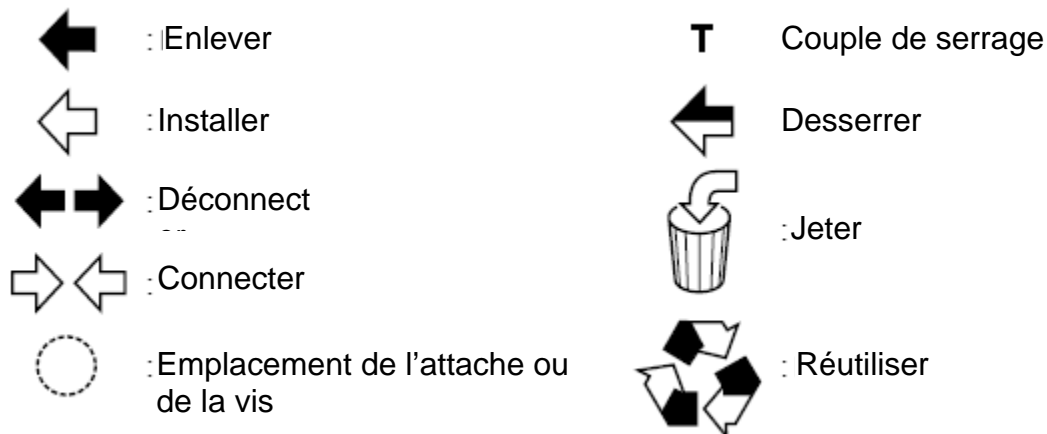

Préparation de la surface

1.

Assurez-vous que les surfaces de montage (montrées ici) sont propres, sans tache, graisse ou résidu. Utilisez la lingette imbibée d'alcool isopropylique fournie (C). Inspectez le véhicule pour déceler toute trace de dommage avant de poser l'écran inférieur de pare-chocs avant. Avant de commencer, veillez à ce que le véhicule et l'écran inférieur soient à la température ambiante. Si la température est inférieure à 16 °C (60 °F) ou supérieure à 43 °C (110 °F), laissez le véhicule reposer à l'intérieur jusqu'à ce que le pare-chocs et l'écran inférieur soient tous deux à température ambiante.

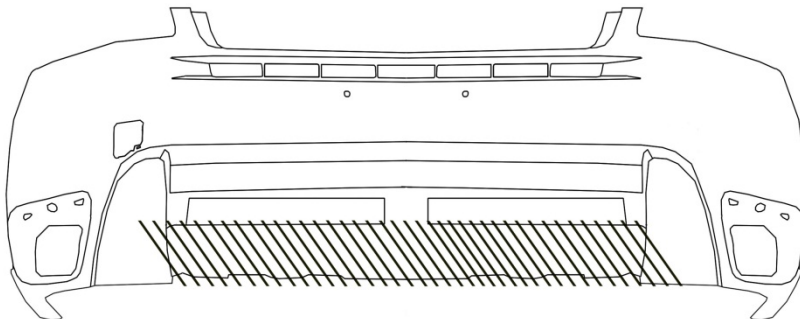

Installation de la moulure avant

(2)

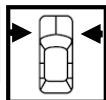

Placez l'écran inférieur de pare-chocs avant (A) sur le pare-chocs en laissant les pattes de tirage dépasser.

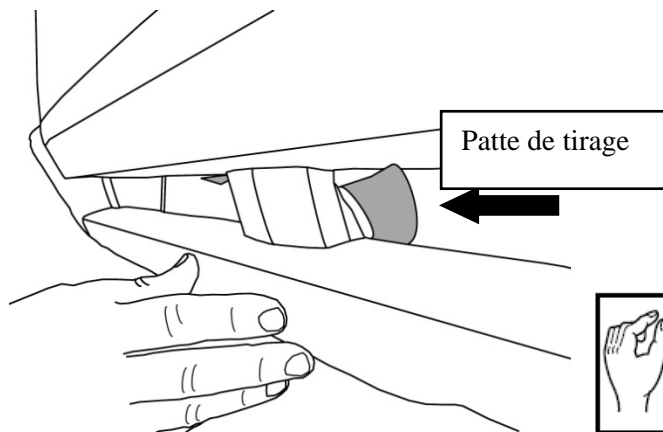

※

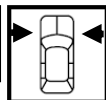

Tirez sur les bandes à partir du centre jusqu'à l'extrémité de la pièce. Vérifiez le positionnement de la pièce, puis exercez une pression de 30 lb-pi² pendant au moins 10 secondes pour la fixer. Prévoyez 24 heures pour que l'adhésif atteigne sa pleine puissance.

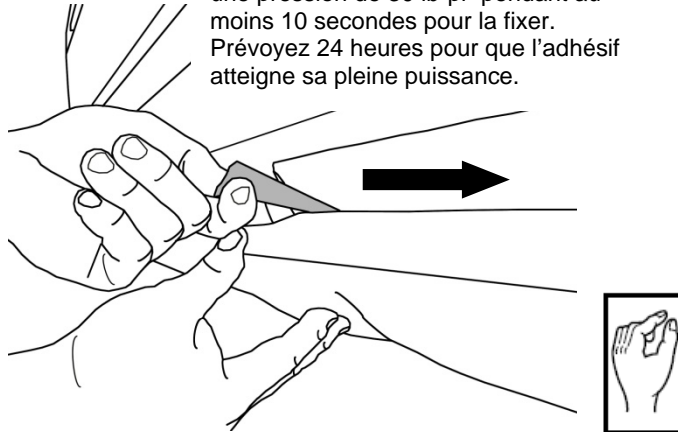

[4
1

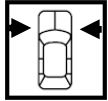

En maintenant fermement la pièce en place, sans laisser d'interstices aux extrémités, utilisez une mèche de 5/16 po munie d'une butée de 1/2 po pour percer 5 orifices de montage de 5/16 po dans les trous existants sur la partie inférieure de la pièce jusqu'à dans le pare-chocs, aux endroits indiqués.

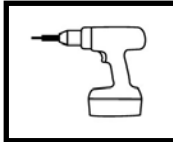
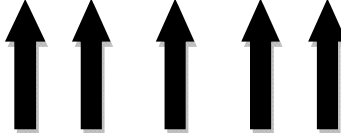
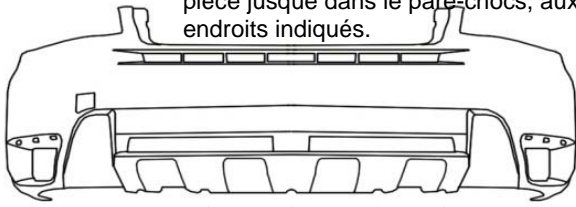

5

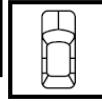

Posez les chevilles (B) dans les trous percés sous la pièce, jusqu'à dans le véhicule.

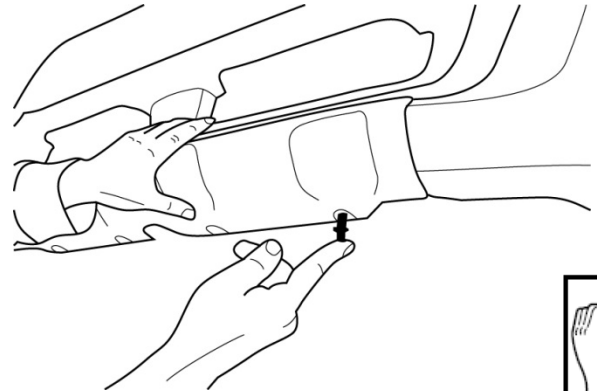

6



L'installation est terminée.

